

SONOREX SUPER

Ultrasonic baths for aqueous fluids



Valid for:

RK 31, RK 31 H, RK 52, RK 52 H
RK 100, RK 100 H, RK 102 H, RK 103 H, RK 106
RK 156, RK 156 BH
RK 170 H
RK 255, RK 255 H
RK 510, RK 510 H, RK 512 H
RK 514, RK 514 H, RK 514 BH
RK 1028, RK 1028 H, RK 1028 C, RK 1028 CH
RK 1040, RK 1050, RK 1050 CH



Copyright & limitation of liability

This document may not be reproduced, either in full or in extracts, without prior approval of BANDELIN electronic GmbH & Co. KG, hereinafter referred to as BANDELIN.

The German original is the binding version of this document. Any difference in the translation is not binding and has no legal effect. In case of any discrepancies between the translation and the original of this document, the original version has priority.

BANDELIN accepts no responsibility or liability for damages caused by improper handling or usage contrary to the intended purpose.

The documentation was prepared with great care. Liability for indirect or direct damages arising because of incomplete or erroneous information in this documentation, as well as in its delivery and usage, is excluded.

All images are provided as examples and are not true to size. Decorative elements are not included in the scope of delivery.

© 2019

BANDELIN *electronic* GmbH & Co. KG, Heinrichstrasse 3–4, Germany, 12207 Berlin,

Tel.: +49-30-768 80 - 0, Fax: +49-30-773 46 99, info@bandelin.com

General

The device, the accessories and the preparations are to be used in accordance with the operating instructions and/or the product information.

The instructions are part of the scope of delivery and are to be stored in the vicinity of the device for later reference. This also applies if possession of the device is transferred.









Before the device is put into operation, these User Instructions are to be read carefully and completely in order for the user to become familiarised with all functions.

The warnings and safety precautions (chapter 1.5) are always to be followed during use.

The manufacturer will not assume any responsibility for the device's safety or functional ability in the event of improper handling or usage contrary to the intended purpose. In the event of unauthorised alterations/modifications, both the warranty claim and the CE conformity will expire.

If service is required, please contact the specialist dealer in charge or the manufacturer.

Symbols used:

Symbol	Significance	Explanation
	Danger	Identifies information that could signify a risk to life and limb, especially through electric shock, if not observed.
	Caution	Identifies information that is to be observed and adhered to without fail, to prevent damage to the device and danger to the user. When device parts are labelled with this symbol, reference must be made to the documentation.
	Warning	Warning
	Important	Identifies information that is important for execution.
	Note	Identifies information provided for explanatory purposes.
	Medical note	Identifies information that is important for medical use.
	Do not grip inside	For health reasons, touching the oscillating fluid is prohibited.
	Wear ear protectors	For health reasons, standing for long periods of time in the vicinity of the device without ear protectors is prohibited.
	Operating sequence instructions	Identifies instructions that are to be followed in the described sequence.

Contents

1	Product description	6
1.1	Mode of operation	6
1.2	Purpose	7
1.3	CE conformity	7
1.4	Technical data	8
1.4.1	Electromagnetic ambient conditions (EMC)	9
1.5	Warnings and safety precautions	10
2	Preparation	11
2.1	Scope of delivery	11
2.2	Set-up / assembly	11
2.3	Start-up	11
3	Operation	12
3.1	Operating elements	12
3.1.1	Ultrasound	12
3.1.2	Heating	13
4	Use	14
4.1	Instructions for use	14
4.2	General use	16
4.3	Treatment of medical and dental instruments	19
4.4	Further information	20
4.4.1	Degassing	20
4.4.2	Disposal of sonication fluids	20
5	Cleaning and maintenance of the ultrasonic bath	21
5.1	Cleaning and care	21
5.2	Disinfection for medical applications	21
5.3	Warehousing / storing	21

6	Maintenance and repair	22
6.1	Maintenance	22
6.2	Functional checks	22
6.3	Error analysis	22
6.4	Repairs and service	23
7	Accessories	24
7.1	Required accessories	24
7.2	Preparations	24
8	Taking the unit out of service	25

Informative appendices

A	Accessories
B	Foil test
C	Dosing table

1 Product description

Ultrasonic bath of type SONOREX SUPER RK

The exact type specification and serial number are found on the type plate, on the rear side of the ultrasonic bath.

Product features:

- Stainless steel oscillating tank (1) with transducers, ultrasound frequency 35 kHz
- Time switch for 1 - 15 min and continuous operation (2)
- Filling level mark for safe filling (3)
- Compact, easy to clean stainless steel housing (4)
- Rubber feet for safe positioning (5)
- As of type RK 102 H, drain outlet with ball valve (6) for easy discharge of bath liquid and handles (7)
- Depending on model, comes with heating (type "H") or a special oscillating tank (types "C")

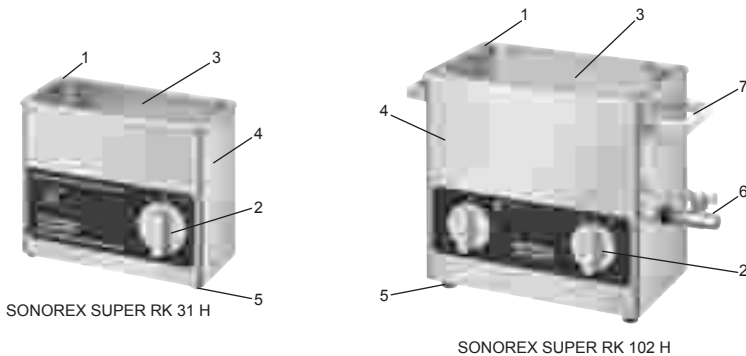

1.1 Mode of operation

SONOREX ultrasonic baths use the effect of cavitation. Under their oscillating tank bottoms they contain piezoelectric transducers, the energy of which is transferred to the bath liquid with ultrasound frequency as mechanical oscillations. As a result, microscopically small bubbles are continuously formed in the bath liquid, which release energy upon imploding and generate local micro currents. This process is called cavitation. During cleaning processes, it causes contamination to be regularly "blasted" from the hard surfaces of the objects being treated. At the same time, dirt particles are dispersed and fresh bath liquid flows in. During sonochemical processes, cavitation may have a catalytic effect, e.g. with the production of stable emulsions or the rapid degasification of fluids with a high gas content.

SONOREX ultrasonic baths are efficiently supported by SweepTec® automatic frequency control. SweepTec® immediately balances load-dependent working point fluctuations to the optimal working point using fast frequency modulation. This produces an especially homogeneous and uniform ultrasound field in the bath volume for constantly reproducible results.

1.2 Purpose

General application

SONOREX ultrasonic baths are intended for the sonication of aqueous fluids. They work on the basis of low-frequency ultrasound and can be used in versatile ways. Their main application is gentle and intensive cleaning of objects of diverse shapes, types and sizes. Alternatively, chemical processes can be favourably supported and accelerated in an ultrasonic bath, e.g. when preparing or treating samples.

Sonication is always carried out in connection with a suitable preparation that is added to the bath liquid. In order to use the device as intended, a basket or another inset beaker, into which objects are placed during sonication, is also required. Only in this manner is the optimum diffusion of the ultrasound guaranteed.

The ultrasonic bath is operated from the front. The operation is usually carried out on a table.



Ultrasound treatment of medical instruments

SONOREX ultrasonic baths are used to treat medical instruments:

- a) during manual treatment
- b) before machine treatment
- c) after machine treatment

In this connection, they are to be used together with suitable, non-fixative disinfection and/or detergent preparations, in order to support or expedite their effect. Pursuant to section 2, para. 1 and section 3, paras. 1, 9 and 10 of the Medical Devices Act (MPG), the ultrasonic bath thus becomes a medical device as an accessory to the preparations, and is to be treated as one. This includes pre- and post-processing steps for the medical instruments, e.g. the observance of KRINKO¹ recommendations in "Hygiene requirements for the treatment of medical products" and other applicable domestic regulations. Additional information in this respect can be found in chapter 4.3.

1.3 CE conformity

SONOREX ultrasonic baths are declared as medical products² and satisfy the CE marking criteria for the European

- "Medical Device" directive
- "Low-voltage directive"
- "Electromagnetic compatibility" directive
- WEEE - Directive

in their currently valid versions.

A declaration of conformity can be requested from the manufacturer by providing the serial number.

¹ In Germany: Empfehlung der Kommission für Krankenhaushygiene und Infektionsprävention (KRINKO) beim Robert Koch-Institut (RKI) und des Bundesinstitutes für Arzneimittel und Medizinprodukte (BfArM); Bundesgesundheitsblatt - 2012+55:1244-1310.

² Exception: see "Technical data" overview

1.4 Technical data

SONOREX ultrasonic baths are interference-free and CE-marked.

Safety: EN 61010-1,

EMC: EN 61326-1

Mains supply: 230 V~ (± 10 %) 50/60 Hz, (115 V upon request),
mains cable length 2 m

Protection class: Class I

Frequency: 35 kHz

Oscillating tank: Stainless steel

Serial number (SN): See type label

Degree of protection: IP 32 according to DIN 60529



Protected against access by instruments to dangerous components, protected against solid foreign bodies with a diameter of 2.5 mm or larger

Protected from dripping water up to 15° from its vertical axis

Ambient conditions according to EN 61 010-1

Overvoltage category: II

Degree of contamination: 2

Permissible ambient temperature: 5 to 40 °C

Permissible relative humidity up to 31 °C: 80 %

Permissible relative humidity up to 40 °C: 50 %

No dewing.

Only for indoor operation.

Bath type	Order No.	Interior dimensions (L × W × D)	Operating volume	Outlet (valve)	Ultrasonic peak power* / Ultrasonic nominal output	Weight (net)	Heating power	Current consumption (230 V)	Current consumption (115 V)
		mm	l		W / W _{eff}	kg	W	A	A
RK 31	329	190 × 85 × 60	0.6	-	160 / 40	2.2	-	0.2	0.4
RK 31 H	7523	190 × 85 × 60	0.6	-	160 / 40	2.3	70	0.5	1.0
RK 52	311	150 × 140 × 100	1.2	-	240 / 60	2.4	-	0.3	0.6
RK 52 H	164	150 × 140 × 100	1.2	-	240 / 60	2.6	140	0.9	1.8
RK 100	301	240 × 140 × 100	2.0	-	320 / 80	3.2	-	0.4	0.7
RK 100 H	312	240 × 140 × 100	2.0	-	320 / 80	3.4	140	1.0	2.0
RK 102 H	303	240 × 140 × 100	2.0	G ¼	480 / 120	4.1	140	1.2	2.3
RK 103 H	326	240 × 140 × 150	2.5	G ¼	560 / 140	4.3	200	1.5	3.0
RK 106	306	∅ 240 × 130	4.0	G ¼	480 / 120	5.2	-	0.6	1.1
RK 156	305	500 × 140 × 100	4.0	G ¼	640 / 160	6.0	-	0.7	1.4
RK 156 BH	646	500 × 140 × 150	6.0	G ¼	860 / 215	7.3	600	3.6	7.1
RK 170 H	7506	1000 × 200 × 200	26.0	G ½	1520 / 380	26.2	1600	8.7	17.3
RK 255	3066	300 × 150 × 150	3.8	G ¼	640 / 160	4.8	-	0.7	1.4
RK 255 H	316	300 × 150 × 150	3.8	G ¼	640 / 160	5.0	280	2.0	3.9
RK 510	327	300 × 240 × 150	6.6	G ½	640 / 160	7.2	-	0.7	1.4
RK 510 H	321	300 × 240 × 150	6.6	G ½	640 / 160	7.4	400	2.5	4.9

Bath type	Order No.	Interior dimensions (L × W × D)	Operating volume	Outlet (valve)	Ultrasonic peak power* / Ultrasonic nominal output	Weight (net)	Heating power	Current consumption (230 V)	Current consumption (115 V)
		mm	l		W / W _{eff}	kg	W	A	A
RK 512 H	795	300 × 240 × 200	8.7	G ½	860 / 215	8.3	400	2.7	5.4
RK 514	277	325 × 300 × 150	9.0	G ½	860 / 215	8.8	-	1.0	1.9
RK 514 H	207	325 × 300 × 150	9.0	G ½	860 / 215	8.8	600	3.6	7.1
RK 514 BH	263	325 × 300 × 200	12.5	G ½	860 / 215	9.8	600	3.6	7.1
RK 1028	322	500 × 300 × 200	19.0	G ½	1200 / 300	14.0	-	1.4	2.7
RK 1028 C	661	500 × 300 × 300	30.0	G ½	2000 / 500	24.5	-	2.2	-
RK 1028 H	324	500 × 300 × 200	19.0	G ½	1200 / 300	14.7	1300	7.0	14.0
RK 1028 CH	143	500 × 300 × 300	30.0	G ½	1200 / 300	23.4	1450	7.7	15.3
RK 1040	319	∅ 500 × 195	28.0	G ½	1520 / 380	19.4	-	1.7	3.4
RK 1050	323	600 × 500 × 200	41.0	G ½	2400 / 600	30.0	-	2.7	5.3
RK 1050 CH	184	600 × 500 × 300	60.0	G ½	2400 / 600	36.0	1950	11.1	17.9

/* In order to improve the effect the ultrasound is being modulated whereby a 4-fold ultrasonic nominal output value is yielded as ultrasonic peak power.



Specifications for use as a medical device

Name: Ultrasonic bath
 UMDNS nomenclature (ECRI / DIMDI): 14-263
 Purpose: See chapter 1.2.
 Classification (Medical Device)
 Directive 93/42/EEG, Appendix IX): Class I; active, non-invasive, non-implantable medical device
 Type, model, serial number, year of manufacture: See type plate on the rear side for information

The ultrasonic bath has been inspected pursuant to norms currently in effect and is to be installed and put into operation pursuant to EMC directions.

Specifications pursuant to the Medical Devices Operator Ordinance (MPBetreibV):

Startup on location, functional check and personnel training (section 4): not required
 Technical safety controls, (STK, section 11): no specifications
 Technical measurement controls, (MTK, section 14): not applicable

1.4.1 Electromagnetic ambient conditions (EMC)

The device was tested to DIN EN 61326-1 for electromagnetic compatibility (EMC) and complies with the requirements for class B devices according to EN 55011.

It is suitable for use in facilities and areas which are directly connected to a public low-voltage supply network, e.g. medical laboratory facilities.

It may generate radio interferences or disrupt the operation of devices nearby. It may be necessary to take remedial measures such as realigning the device or a reconfiguring the ultrasonic bath or the shield.

During operation, portable or mobile HF communication systems in the vicinity of the ultrasonic bath should be turned off - their operation may be disrupted.

1.5 Warnings and safety precautions

General

- Keep the ultrasonic bath out of the reach of children and persons who have not been instructed in its operation by reference to these instructions.
- We will not offer a guarantee for damages to the ultrasonic bath or oscillating tank, or to the objects to be treated, as a result of use of inadequate disinfection agents or detergents.
- Keep the surface of the ultrasonic bath and operating elements clean and dry.
- Do not expose the ultrasonic bath to corroding influences.
- Move the ultrasonic bath only when it is empty.
- Empty the ultrasonic bath only while turned off.
- Ultrasonic baths adhere to prescribed EMC limit values, such that it can be assumed that the electromagnetic radiation emanating from the units is harmless to humans. A binding statement for wearers of implants can only be made at the place of work and together with the implant manufacturer, however. In case of doubt, information regarding the allowable electromagnetic exposure level is to be obtained from the implant manufacturer.

Operation

- Observe ambient and set-up conditions, see chapter 1.4.
- Only plug in the ultrasonic bath to an outlet with a grounded socket.
- Do not operate the ultrasonic bath without fluids.
- Do not stand or lay any objects on the tank bottom, accessories must be used, see chapter 7.
- Do not immerse any parts of the body (e.g. hands, feet) or living beings (animals or plants) into the tank; in particular, do not immerse them in the ultrasonic fluid during ultrasound operation.
Danger: Ultrasounds have a cell-destroying effect.
- In the event of continuous activity within a 2 m radius, adequate hearing protection must be used. Danger: Hearing disturbances during operation when not wearing hearing protection - the typical ultrasound cavitation noise can be very uncomfortable.
- When preheating the bath liquid, stir at least every 15 min. or switch on the ultrasound. Danger: Scalding due to retardation of boiling.
- Do not operate the ultrasonic bath while unattended.



Advice for the medical field

- The ultrasonic bath is exclusively intended for use by medical skilled personnel.
- When handling contaminated instruments, relevant personnel protection regulations are to be observed.
- When treating instruments, the instructions of the instrument manufacturer are to be followed.
- Ultrasound cleaning is especially suited for instruments made of stainless steel and hard plastics. Do not treat lenses, camera systems or light cables with ultrasound.

Damages

- If damage to the ultrasonic bath is detected, do not connect the ultrasonic bath to the mains.
- In the event of defects, disconnect the power plug immediately.
- Repairs are only to be conducted by authorised skilled personnel or by the manufacturer.
- Defective parts may only be replaced with original SONOREX parts.

2 Preparation

Carefully unpack the ultrasonic bath and accessories and inspect them for completeness or possible transportation damages. If any damages or defects are found, these are to be immediately notified in writing to the transportation company and to the supplier.

Before startup, the ultrasonic bath is to be left to stand at its operating location for 2 hours so that it may adapt to the ambient conditions.

2.1 Scope of delivery

- 1 Ultrasonic bath, optionally with heating - see delivery note
- 1 Ball valve (brass, galvanized) with hose, as of type RK 102 H, packaged separately with sealing tape and assembly instructions
- 1 Instruction manual

Additional accessories according to order - see delivery note

2.2 Set-up / assembly

- Place the ultrasonic bath atop a firm, level and dry surface. In doing so
 - observe the maximum weight of the ultrasonic bath, including fluid. Net weight see technical data chapter 1.4.
 - do not block the air supply below the ultrasonic bath.
 - guard against moisture and wetness - risk of electric shock.
- In the case of ultrasonic baths with a drain outlet, mount the ball valve, hose socket and hose, which are included in the delivery, pursuant to the enclosed assembly instructions.



2.3 Start-up

- Thoroughly rinse the ultrasonic bath's oscillating tank with water before its first use.
- Verify that the control buttons are in the "off" position, i.e. the switch indicator above or the toggle switch is set to "0", then connect the ultrasonic bath to the mains (grounded socket).
- Conduct function test - briefly plug in the ultrasound (maximum of 1 to 2 seconds), a hissing noise should be heard. Set to "0" once again.
- It is recommended that a foil test be conducted as part of quality assurance prior to the first use.
This test is to be saved for later comparison, see appendix for information.
- If applicable, hang accessories in the ultrasonic bath and place lid on top.

3 Operation

3.1 Operating elements

The ultrasound and the heating system are operated from the front:

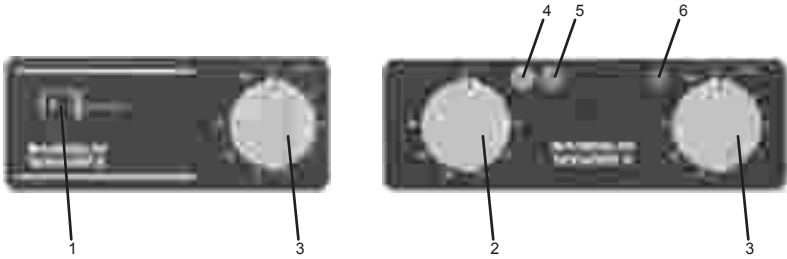

- 1 Toggle switch for heating ON / OFF incl. control light (only type "RK 31 H")
- 2 Turning knob for heating ON / OFF incl. adjustment control (only as of type "RK 52 H")
- 3 Turning knob for ultrasound ON / OFF with preset time
- 4 White control light (heating system is activated)
- 5 Yellow control light (heating system in operation - from RK 100 H)
- 6 Green control light (ultrasound in operation)

The layout of the control lights depends upon the ultrasonic bath.

3.1.1 Ultrasound

The ultrasound is operated through the turning knob (time switch).

Timed operation:

- Turn knob to the right
→ range of time 1 - 15 minutes
 - Green control light flashes.
 - Once the time has elapsed, the time switch will automatically turn off.
- By turning the knob back, the operating time will be shortened, i.e. the ultrasonic bath will be turned off.

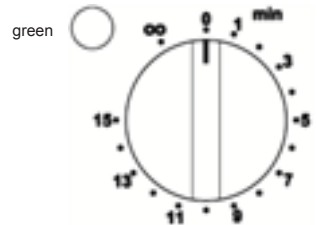

Continuous operation:

- Turn knob to the left
→ Setting ∞
 - Green control light flashes.
 - The ultrasonic bath will not turn off automatically, to switch it off turn the knob left, back to "0".



Notes

- While turned off, the ultrasonic bath may remain connected to the mains. It can be disconnected from the mains by pulling the mains plug.
- An "engaging" of the time switch is barely felt if mains voltage is not present, e. g. if the mains plug is disconnected or the fuse is blown. The time switch only works if mains voltage is present.

3.1.2 Heating

The heating system is operated through the integrated toggle switch or turning knob.

- Switch on toggle switch
→ Fixed setting 65 °C

- The yellow control light in the switch will flash.
- Press the switch to turn it off (a "0" becomes visible)

RK 31 H: Toggle switch



If a bath temperature of approx. 65 °C is reached, the heating will turn off - the control light will continue to flash.

- Turn knob to the right
→ Temperature range 30-80 °C:
 - To turn it off, turn the knob left back to "°C".

RK 52 H (a white lamp):

- The white control lamp comes on during the heating phase and goes out when the set temperature is reached.

From RK 100 H:

- The yellow and white control lights will flash.
- The yellow control light goes out when the set temperature is reached.

RK 100 H: Turning knob

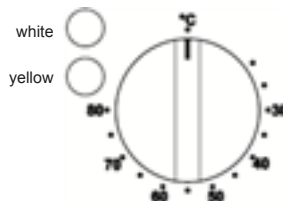

Notes

- The heating system works independently from the ultrasound.
- The heating will automatically turn on every time that the bath temperature drops below the set temperature.
- The heat automatically switches off to protect the ultrasonic bath from overheating. The ultrasonic bath will need to cool down sufficiently (water temperature around 50 °C) and be disconnected from the mains power briefly before it can be used again.
- Ultrasound energy warms up the sonication fluid (even without additional heating).
 - In case of continuous sonication and/or covering the oscillating tank, the fluid temperature will increase, even rising above the value set on the thermostat. For this reason, check the temperature when treating temperature-sensitive components.
 - Non-aqueous fluids can heat up many times faster than water. A possible flashpoint can be reached and/or exceeded after a very short sonication time. In the case of high-boiling liquids (with and without a flashpoint), the bath temperature can increase to >120 °C due to the energy input of the ultrasound. This leads to irreparable damage to the ultrasonic bath.

4 Use

Direct sonication

Normally, sonication takes place **directly** in the oscillating tank. For this purpose, the objects to be treated are placed in a basket and hung inside the oscillating tank which is filled with sonication fluid.

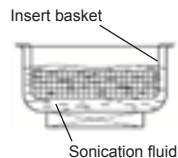

Indirect sonication

Indirect sonication in inset beakers is to be conducted for special applications or to protect the stainless steel oscillating tank in the case of:

- Sonication of sample fluids.
- Use of chemically aggressive fluids (e.g. using acids as cleaning agents).
- Removal of chemically aggressive soiling (e.g. cleaning of developing machine racks).
- Removal of abrasive contamination (e.g. polishing pastes, quartz, sand).

For indirect sonication, a contact liquid (water + surfactants) must be filled in between the inset beaker and the oscillating tank.

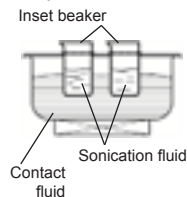

4.1 Instructions for use

Instructions - filling

- For ultrasonic baths with outlet, verify that the ball valve is closed.
- Ultrasound and heating must be turned off.
- Do not fill ultrasonic tank with hot water. Maximum filling temperature: 50 °C.
- At least drinking-quality water must be used to fill the oscillating tank.
- Water without additives is not suited for sonication. BANDELIN recommends the TICKOPUR or STAMMOPUR preparations.
- Only use distilled or deionised water without additives in inset beakers or insert tubs.
- The fill level must always be at or slightly above the filling level mark. A low fill level will damage the ultrasonic bath!
- Do not use any combustible, explosive, non-aqueous liquids or azeotropic mixtures directly in the stainless steel oscillating tank (e.g. benzene, solvents). Furthermore, chemicals that contain or that separate chloride ions (some disinfectants, household cleaners, and dish detergents), may not be used directly in the stainless steel tank.
- When working with aggressive preparations in inset beakers or insert tubs: Prevent the contact liquid or stainless steel surfaces from being sprayed. If necessary, replace the contact liquid, clean the surfaces and wipe dry.
- When using strongly acidic preparations, the hard chromium plating of the ball valve may become corroded and the ball valve start to leak. If the use of a strongly acidic cleaning agent cannot be avoided, the use of a stainless steel ball valve is recommended.
- When using preparations, the safety instructions included in the product leaflets are to be fundamentally adhered to.
- Replace used sonication fluids, do not refresh by adding fluids.



Notes - Inserting objects

- Fully remove air bubbles from cavities (e.g. blind holes).

Indirect sonication

Remove any air bubbles from underneath the vessels.



Notes - Temperature and heating

- Warmed-up fluids intensify the ultrasound effect. Experience has shown that the best results are obtained with a bath temperature of 50 to 60 °C. With high temperatures, the effect of the ultrasound cavitation decreases; however³.
- In order to save time during use, the bath fluid may be preheated during degassing.
- For an optimum bath temperature, observe the specifications of the specimen manufacturer!
- To protect the electronic components inside the ultrasonic bath, the ultrasound output is reduced upon reaching a critical temperature in order to inhibit a further increase in the interior temperature.
- The fluid in the oscillating tank may not exceed a maximum operating temperature of 100 °C.
- Prepare the disinfectant with cold water, operate the ultrasonic bath without heating and avoid temperatures above 40 °C.



4.2 General use

Step 1: Fill oscillating tank

The oscillating tank is filled with water and a suitable preparation to reduce the surface tension, see chapter 7.2.

Direct sonication

- Fill 1/3 of oscillating tank with water.
- Add dosed preparation to the oscillating tank. See appendix for dosage information.
- Fill carefully up to the filling level mark, avoid as much as possible the formation of foam.



Indirect sonication

When using aggressive acidic liquids (e.g., sulfuric acid, hydrochloric acid), we recommend using alkaline contact liquid such as 5% TICKOPUR R 33.

- Fill 1/3 of oscillating tank with water.
- Surfactant.
- Fill carefully, avoid as much as possible the formation of foam. The oscillating tank must be filled contingent upon the inset beaker since inset beakers displace the contact liquid.



Step 2: Degassing the fluid

Freshly-filled bath fluid or fluid that has remained in the oscillating tank for a longer period of time must be degassed prior to use. See also chapter 4.4.1.

- Remove basket and other accessories from the oscillating tank.
 - Place lid on top.
 - For degassing, start the ultrasound with the turning knob, see chapter 3.1.1
 - up to 10 litres bath volume: 10 min
 - more than 10 litres bath volume: 30 min
- Time need to be extended with acidic cleaning solutions.

Step 3: Preheat fluid

In ultrasonic baths with built-in heating, the fluid may be preheated independently of the ultrasound. This increases the ultrasound effect, especially when removing fats, oils and polishing paste residue, and shortens the duration of the subsequent ultrasound.

- Remove basket and other accessories from the oscillating tank.
- Place lid on top.
- Using the turning knob, set the desired temperature, see chapter 3.1.2.
- For an even warming of fluids, stir the fluids or switch on the ultrasound for a few minutes now and then, otherwise there will be a retardation of boiling - risk of scalding!

Step 4: Insert objects to be treated

Before every sonication it is necessary to check whether the sonication fluid needs to be cleaned or replaced.

Direct sonication

- Hang the insert basket with the goods to be treated, or place the basket holder in the oscillating tank. Place the inset basket on the basket holder.
- Check that the objects to be treated are fully covered with fluid.
- With every object inserted, the fill level is to be controlled.

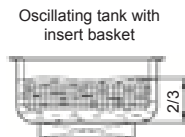

Indirect sonication

- Place the positioning lid atop the oscillating tank and hang the inset beakers from the positioning lid, or hang the insert tub directly in the oscillating tank.
- Immersion depth for inset beakers is min. 2 cm.
- Control fill level (contact liquid).

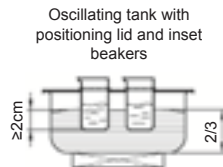

For cleaning tasks

Place the objects to be cleaned in the appropriate accessories, in doing so please note:

- Evenly distribute parts, do not stack them.
- An overloading of the basket or inset beaker reduces the ultrasound effect (the ultrasound is absorbed).
- Place the more heavily soiled side facing downward.
- Parts with joints are to be fully opened before placing inside.
- Delicate parts are not to come into contact with one another - for positioning, use special accessories such as silicone knob mats if necessary, see chapter 7.
- Due to the design, the ultrasound effect is weaker on the outlet side. Heavily contaminated objects should not be placed in the basket over the outlet.

For indirect sonication of fluids

Fill sample vessel(s), in doing so please note:

- It is possible to treat multiple sample vessels with different fluids at the same time.
- When treating small quantities of combustible fluids in sample vessels, the country-specific guidelines/regulations that are currently in effect are to be observed.

Step 5: Ultrasound - Operation

Fundamentally, the sonication time is to be as short as possible in order to protect the objects to be treated and the oscillating tank.

In the case of disinfection fluids, the length of time will depend on the concentration of the respectively used preparation.

In the case of stubborn residue, conduct sonication for a longer time if necessary.

- Place lid on top.
- Using the turning knob, set the desired sonication time, see chapter 3.1.1.



Step 6: Removing treated objects

After sonication, the objects are to be removed from the ultrasonic bath. Allowing them to remain any longer in the bath fluid may damage them.

- Switch off the ultrasound.
- Remove the basket or inset beaker from the tank and set down atop a level surface.



Caution

Depending upon the set temperature or the duration of sonication, the baskets and objects may be hot!

- After the cleaning processes, rinse the treated objects with water of at least drinking quality. Visually review the sonication results.
- Before the next sonication, verify the service life (see chapter 4.4.2) of the bath fluid. Heed the specifications of the preparation manufacturer. If necessary, empty the oscillating tank.

Step 7: Empty the oscillating tank

Layers of contamination on the tank bottom reduce the ultrasonic output.

The oscillating tank is to be emptied after a long period of use or sonication of heavily soiled objects, see chapter 4.4.2.



- Switch off ultrasound.
- Pull the power plug.
- Do not place the ultrasonic bath in the sink.
- Empty the oscillating tank, to do this
 - Ultrasonic baths with outlet
Place ball valve handle in direction of discharge to open outlet.
 - Ultrasonic baths without outlet
Pour out tank contents over the (rear left) corner.
In doing so, avoid splashing the ultrasonic bath from below.
- After emptying the oscillating tank, thoroughly rinse it. Rub dry with a soft cloth.
For additional care instructions, see chapter 5.

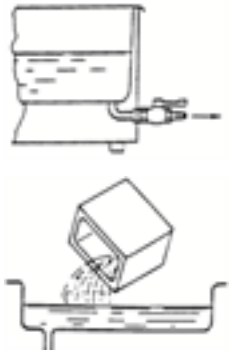

4.3 Treatment of medical and dental instruments



- The disinfection and cleaning of medical instruments in a single step follows the general sonication procedure, see chapter 4.2.
- A combined disinfection and cleaning of medical instruments in the ultrasonic bath is only possible with the use of special preparations (with the corresponding microbiologic certificates). An ultrasound alone will not disinfect them!
- Only disinfection agents and/or detergents that are non-affixing may be used.
- In terms of concentration, temperature, and sonication time, the manufacturer specifications for the disinfection agent and/or detergent used are to be strictly adhered to.
- The compatibility between the instrument and the preparation is to be verified on the basis of the respective manufacturer's specifications.
- The service life of the disinfection solution pursuant to the manufacturer specifications is to be heeded.
The cleaning solution is to be immediately replaced if contamination is evident. It is to be replaced, however, at least every work day.
- Prepare instruments appropriately, e.g. by rinsing them with cold water of at least drinking quality, fully separating / opening them!
Adhere to the instructions of the respective instrument manufacturer.
- Operate the ultrasonic bath with a lid or below and/or atop a suctioning system.
- Further treat instruments after sonication in accordance with KRINKO⁴ recommendations. In other countries, the relevant supplementary/divergent national regulations should be taken into account.
- Adhere to OSHA safety measures (e.g. protective clothing, protective goggles, suitable gloves).

Special case "thorough cleansing"

In the case of stained, crusted or oxidised instruments, a thorough cleansing is recommended. The thorough cleansing is carried out as indirect sonication in a plastic insert tub, using a special detergent (see chapter 7.2).

⁴ In Germany: Empfehlung der Kommission für Krankenhaushygiene und Infektionsprävention (KRINKO) beim Robert Koch-Institut (RKI) und des Bundesinstitutes für Arzneimittel und Medizinprodukte (BfArM); Bundesgesundheitsblatt - 2012+55:1244-1310.

4.4 Further information

4.4.1 Degassing

Degassing the sonication fluid increases the ultrasound effect.

Freshly filled-in fluid or fluid that has remained in the oscillating tank for a longer period of time must be degassed prior to use. Gases released in the fluid (e.g. oxygen) are reduced through degassing and the ultrasound effect is thus significantly improved.

The cavitation noise changes during degassing, loud degassing noises disappear at the end of the degassing process, the ultrasonic bath appears to work more quietly.

A lower noise level, however, does not mean a reduction in ultrasonic power. It rather means the end of the degassing process and an improvement in the ultrasound effect.

4.4.2 Disposal of sonication fluids

The working solution is disposed of pursuant to the specifications in the product leaflet and the label supplied by the manufacturer of the preparations employed. All aqueous preparations made by DR H. STAMM GmbH are prepared pursuant to the regulations of the German Washing and Cleansing Agents Act, are biodegradable and as working solutions may be disposed of in the wastewater. Strongly acidic and strongly alkaline fluids are to be previously neutralised pursuant to technical data sheet specifications. The manufacturer's specifications for the respective preparations should be observed.

During cleaning, materials hazardous to water such as oils, heavy metal compounds, etc., depending on the type of contamination, may enter the working solution. If the limit values are exceeded, the working solution must be reconditioned (removal of contaminants) or be disposed of as toxic waste.

Disinfection and cleaning agents that become contaminated when used are considered "waste material" pursuant to the German Waste Act (AbfG) and may not be taken back by the manufacturer. In other countries, the relevant supplementary/divergent national regulations should be taken into account.

In every case, the statutory provisions and regulations of municipal wastewater plants must be adhered to. Information is provided by municipal wastewater plants as well as by environmental agencies.

5 Cleaning and maintenance of the ultrasonic bath

To achieve an optimum lifespan for the ultrasonic bath, cleaning and maintenance are to be conducted regularly.



CAUTION!

Disconnect the ultrasonic bath from the mains before cleaning / maintenance.



Do not rinse or immerse the ultrasonic bath in water, and do not expose it to splash water.

No guarantee will apply to damage caused by the use of unsuitable surface disinfection agents or detergents.

5.1 Cleaning and care

Oscillating tank

The oscillating tank of an ultrasonic bath is a wear part.

It is continuously exposed to cavitation during ultrasound operation. Dirt particles remaining in the tank abrade and damage the tank surface through the movement of the fluid, therefore

- Thoroughly and frequently rinse the oscillating tank with water and rub dry using a soft cloth.
- Regularly remove residue from the edges of the oscillating tank using a commercial stainless steel cleaning product without any abrasive additives.
- Do not use steel wool, scrapers or graters for cleaning / maintenance.
- Metal particles that remain on the stainless steel surface as well as rust particles from the water pipe system penetrate the passive protective layer of the stainless steel. The stainless steel is "activated" in this process and it begins to rust. The extraneous rust produces localised corrosion of the stainless steel. For this reason, remove metal parts such as screws, filings, etc. from the oscillating tank, and immediately remove rust stains using a soft cloth and a commercial stainless steel cleaning product without abrasive additives.

Housing

- Do not use any abrasive cleaners, only commercial care products without abrasive additives.
- Housing is to be wiped off only from the outside with a moist cloth; afterwards, allow to dry alone or wipe dry.

5.2 Disinfection for medical applications



If contaminated medical instruments are treated in the ultrasonic bath, hygienic safety after the application is important. In order to avoid any cross-contamination as a result of the colonisation of microorganisms, especially along the tank edge and in the drain outlet area, but also on the operator panel, these areas are to be regularly cleaned and disinfected with a suitable surface disinfectant, i.e. one that is at least bactericidal, yeasticidal and virucidal against enveloped viruses.

Accessories such as holders and baskets should be processed regularly in a cleaning and disinfection unit.

5.3 Warehousing / storing

During long periods of non-use, the ultrasonic bath is to be stored in a cool, dry location. The lid should be placed on top in order to protect the oscillating tank from outside contamination.

6 Maintenance and repair

6.1 Maintenance

SONOREX ultrasonic baths require no maintenance.

For purposes of regular control, the following functional checks may be carried out.

6.2 Functional checks

Checking control lights

- Pursuant to chapters 3.1.1 and 3.1.2.

Checking the ultrasound and/or heating

Function can be checked using a standard wattmeter. It is to be inserted between the ultrasonic bath's power plug and the power outlet.

- Fill the oscillating tank with fluid, see chapter 4.2.
- For testing purposes, only the ultrasound or only the heating system are to be plugged in. Next, the value displayed is to be compared with the corresponding value in the technical data (chapter 1.4) (tolerances $\pm 20\%$).

Checking the ultrasound effect

- For this check, it is recommended that a foil test be conducted. A suitable frame for a foil test can be requested from the manufacturer. Customary aluminium foil is used to conduct the test. Next, a comparison is made with previously-generated foils. For more detailed information, please see the appendix.
- A measurement procedure is described in DIN SPEC 40170:2013-11 (Measurement and judgement of the cavitation noise).

6.3 Error analysis

SONOREX ultrasonic baths are robustly constructed and designed for a high level of reliability. Nevertheless, the possibility of a malfunction due to a defective component can never be fully discounted.

The following overview of possible sources of error should serve as an aid for error detection and elimination.

- Ultrasonic bath oscillates weakly, unevenly, or noise is too loud:
 - Has fluid been properly degassed? \Rightarrow Sonicate for 15 min.
 - Is it overloaded with objects to be treated? \Rightarrow Remove a few parts.
 - Uneven noises (wobbling) \Rightarrow No error - slightly adjust the filling level of the fluid.
- Heating system defective?
The ultrasonic bath can be readily operated without heating.
- Emergence of light erosion on the bottom of the tank? \Rightarrow Natural wear. Ultrasonic bath OK.

Any malfunctions are to be communicated in writing to the manufacturer.

6.4 Repairs and service



CAUTION!

Repair work may only be carried out by authorised, qualified personnel or by the manufacturer. The manufacturer assumes no liability for unauthorised interventions on the ultrasonic bath!

If errors or defects are ascertained as a result of the functional check, and if it is impossible to rectify such errors, the ultrasonic bath may no longer be used. In such a case, please contact the local distributor or the manufacturer:

BANDELIN electronic GmbH & Co. KG
Heinrichstrasse 3-4
12207 Berlin

Repair service:

Tel.: +49 30 768 80-13

Fax: +49 30 768 802 00 13

E-mail:

info@bandelin.com

In the case of returns, the general terms and conditions for delivery and payment of BANDELIN electronic GmbH & Co. KG shall apply.

In addition, the ultrasonic bath is to be cleaned and decontaminated (if necessary), see the following chapter.

Decontamination certificate

If the ultrasonic bath is sent back to the manufacturer for repairs (with accessories, as the case may be), the form "Certificate of Decontamination" is to be filled out and affixed to the packaging on the outside, in a visible spot.

If this form has not been filled out, we reserve the right to refuse receipt of the package in order to protect our employees.

The form can be downloaded from the Internet as a PDF file:
[www.bandelin.com / Download ...](http://www.bandelin.com/Download...)

7 Accessories

The proper accessories facilitate use of the ultrasound and also protect the oscillating tank and objects to be treated.

BANDELIN offers a broad range of accessories, see appendix.

Additional information may be obtained from our supplier, our sales representatives, or from our website.

No-obligation telephone consultation:
+49 30 768 80-0

Internet:
www.bandelin.com

7.1 Required accessories

Required accessories are e.g. baskets, basket holders, positioning lids with inset beakers, etc. For more detailed information, please see the appendix.

Do not stand or lay any objects directly on the tank bottom.

Exceptions to this rule are special baskets and basket holders (e.g. K 6 and SH 7) that have been designed by BANDELIN in such a manner that they are not located in the cavitation field and do not damage the tank bottom.

7.2 Preparations

Special preparations are required for use of the ultrasound that are ultrasound-compatible, i.e. they are cavitation-conducive, biodegradable, easily disposable, gentle to the material, and long-lasting.

BANDELIN recommends the TICKOPUR or STAMMOPUR concentrates by DR. H. STAMM GmbH, which have been especially developed for ultrasound use and which optimally utilise the ultrasound.

Additional information may be obtained from our supplier, our sales representatives, or from our website.

No-obligation telephone consultation:
+49 30 768 80-280

Internet:
www.dr-stamm.de



IMPORTANT!







- When using preparations, the safety instructions on the label and in the respective product leaflet must be adhered to.
- Keep the preparations out of the reach of children and also of persons who have not been instructed in their use by reference to the product information.
- Do not ingest or inhale the preparations, and do not allow them to come into contact with the eyes or skin.
- Specimens in powder form may only be used fully dissolved.

8 Taking the unit out of service

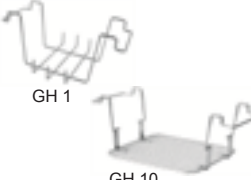





If the ultrasonic bath no longer works, it must be disposed of appropriately.







A Accessories

 A rectangular stainless steel basket with a sieve cloth top and two handles on opposite sides.	<p>Insert basket K ..., made of stainless steel, sieve cloth. Protects objects to be cleaned and prevents damages to the tank bottom. Optimum ultrasound transmission.</p>
 Two stainless steel mesh holders. GH 1 is a larger holder with a flat base and two handles. GH 10 is a smaller holder with a flat base and two handles.	<p>Utensil holder GH ..., made of stainless steel, mesh size 12 x 12 mm, for larger components. GH 1 for flasks up to Ø 105 mm.</p>
 A rectangular stainless steel lid with a central circular opening and two handles on opposite sides.	<p>Lid D ..., made of stainless steel, for use with inserted basket. Protects from exterior contamination. Condensation water is discharged in the oscillating tank. Sound-absorbing</p>
 A rectangular stainless steel basket with a sieve cloth top and two handles on opposite sides, similar to basket K but without the top cloth.	<p>Inset basket K ... EM, made of stainless steel, an alternative to DIN sieve trays in the medical field. KT basket holder required.</p>
 A rectangular stainless steel frame with four legs and two horizontal bars across the top, designed to hold an inset basket.	<p>Basket holder KT ..., made of stainless steel, for inset baskets K...EM or DIN sieve trays in the medical field.</p>
 A rectangular stainless steel lid with a central circular opening and two handles on opposite sides, similar to lid D but without the top cloth.	<p>Lid D ... T, made of stainless steel. These lids (D ... T and D ... P) are especially for the use of inset baskets without brackets (K ... EM).</p>
 A rectangular plastic tub with a lid and four legs, designed for use with chemicals.	<p>Insert tub KW ..., made of plastic, with lid. For use of chemicals that would corrode the stainless steel tank. Observe temperature and chemical resistance of PE (KW 3 ... KW 5) and PP (as of KW 10-0).</p>

Accessories Ultrasonic bath	Insert basket	Utensil holder	Lid D ...	Insert basket	Basket holder	Lid D ... T	Insert tub
RK 31 /H	K 08	-	D 08	-	-	-	-
RK 52 /H	K 1 C	GH 1	D 52	-	-	D 1 T	-
RK 100 /H, RK 102 H	K 3 C	GH 1	D 100	-	-	D 3 T	KW 3
RK 103 H	K 3 CL	-	D 100	-	-	D 3 T	KW 3
RK 106	K 6	-	D 6	-	-	-	-
RK 156	K 6 L	-	D 156	-	-	-	-
RK 156 BH	K 6 BL	-	D 156	-	-	-	-
RK 170 H	K 7	-	D 170	-	-	-	-
RK 255 /H	K 5 C	-	D 255	-	-	D 5 T	KW 5
RK 510 /H	K 10	GH 10	D 510	-	-	D 10 T	KW 10-0
RK 512 H	K 10 B	-	D 510	-	-	D 10 T	-
RK 514 /H	K 14	-	D 514	K 14 EM	KT 14	D 14 T	KW 14
RK 514 BH	K 14 B	-	D 514	-	-	D 14 T	KW 14 B
RK 1028/H	K 28	GH 28	D 1028	K 29 EM	KT 30	D 28 T	KW 28-0
RK 1028 C	K 28 C	-	D 1028 C	-	-	-	KW 28-0
RK 1028 CH	K 28 C	-	D 1028 C	-	-	-	KW 28-0
RK 1040	K 40	-	D 40	-	-	-	-
RK 1050	K 50	-	D 1050 C	-	-	-	KW 50-0
RK 1050 CH	K 50 C	-	D 1050 C	-	-	-	KW 50 B-0

 <p>KD 0 PD 04</p>	<p>Inset baskets KD ..., PD ... Sieve cloth. Compatible with inset beakers. Cleaning of small parts. KD 0 Stainless steel Ø interior 75 mm PD 04 Plastic Ø interior 60 mm</p>
 <p>SD 06 EB 05 PD 06</p>	<p>Inset beakers SD ... (glass), EB ... (stainless steel), PD ... (plastic) for indirect cleaning of small parts, compatible with positioning lid and beaker holder Ø 87 mm. With ring and lid. KB 04, SD 04 and SD 05 Ø 76 mm, without lid. SD 09 without lid.</p>
	<p>Positioning lid DE ..., made of stainless steel, for hanging of inset beakers. Positioning for optimum utilisation of ultrasound energy.</p>
	<p>Beaker holder ES ..., made of stainless steel, to hold 4 inset beakers in larger ultrasonic baths. Positioning for optimum utilisation of ultrasound energy.</p>
	<p>Impression tray holder LT 102, made of stainless steel, for cleaning of impression trays.</p>
	<p>Insert basket PK ... C and K ... P, made of plastic, perforated, for gentle cleaning of sensitive surfaces, e.g. instruments such as probes, syringes, stoppers, etc.</p>
	<p>Injection valve holders ED ..., made of stainless steel, to hang in the oscillating tank. Receipt of injection valve of diverse sizes.</p>

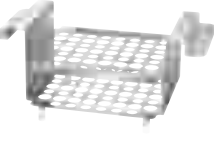
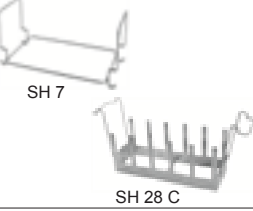
Accessories Ultrasonic bath	Insert basket	Inset beaker	Positioning lid / beaker holders	Impression tray holder	Insert basket	Injection valve holder
RK 31 /H	PD 04	KB 04, SD 05	DE 08	-	-	-
RK 52 /H	KD 0, PD 04	SD 06, SD 09, PD 06, EB 05	DE 52	-	PK 1 C	ED 0
RK 100 /H, RK 102 H	KD 0, PD 04	SD 06, SD 09, PD 06, EB 05	DE 100	LT 102	PK 2 C	ED 9
RK 103 H	KD 0, PD 04	SD 06, SD 09, PD 06, EB 05	DE 100	-	PK 3 C	-
RK 106	KD 0, PD 04	SD 06, SD 09, PD 06, EB 05	DE 6	-	-	-
RK 156	KD 0, PD 04	SD 06, SD 09, PD 06, EB 05	DE 156	-	-	-
RK 156 BH	KD 0, PD 04	SD 06, SD 09, PD 06, EB 05	DE 156	-	-	-
RK 170 H	-	-	-	-	-	-
RK 255 /H	KD 0, PD 04	SD 06, SD 09, PD 06, EB 05	DE 255	-	K 5 P	-
RK 510 /H	KD 0, PD 04	SD 06, SD 09, PD 06, EB 05	DE 510	-	-	ED 9
RK 512 H	KD 0, PD 04	SD 06, SD 09, PD 06, EB 05	DE 510	-	-	-
RK 514 /H	KD 0, PD 04	SD 06, SD 09, PD 06, EB 05	DE 514	-	-	-
RK 514 BH	KD 0, PD 04	SD 06, SD 09, PD 06, EB 05	DE 514	-	-	ED 14
RK 1028/H	KD 0, PD 04	SD 06, SD 09, PD 06, EB 05	ES 4	-	-	-
RK 1028 C	KD 0, PD 04	SD 06, SD 09, PD 06, EB 05	ES 4	-	-	-
RK 1028 CH	KD 0, PD 04	SD 06, SD 09, PD 06, EB 05	ES 4	-	-	-
RK 1040	-	-	-	-	-	-
RK 1050	KD 0, PD 04	SD 06, SD 09, PD 06, EB 05	ES 4	-	-	-
RK 1050 CH	KD 0, PD 04	SD 06, SD 09, PD 06, EB 05	ES 4	-	-	-

	<p>Spring clamps EK ..., made of stainless steel, for laboratory flasks. Prevent them from buoying upwards. To be screwed into insert baskets and utensil holders. EK 10 – 10 ml – max. Ø 31 mm EK 25 – 25 ml – max. Ø 42 mm EK 50 – 50 ml – max. Ø 52 mm EK 100 – 100 ml – max. Ø 65 mm EK 250 – 250 ml – max. Ø 85 mm</p>
	<p>Handle adjustment GV ..., made of stainless steel, for insert baskets and utensil holders</p>
	<p>Test tube holder RG ..., made of stainless steel. For the simultaneous sonication of 6 test tubes of up to Ø 25 mm and 8 test tubes of up to Ø 16 mm. May also be used as a test tube stand. The test tube contents remain visible.</p>
	<p>Tabletting punch holder TH ..., made of stainless steel. Holds tabletting punches of diverse diameters.</p>
 <p>SH 7</p> <p>SH 28 C</p>	<p>Sieve holder SH 7, made of stainless steel. For cleaning of single sieve in RK 106.</p> <p>Sieve holder SH 28 C, made of stainless steel. For the gentle and simultaneous cleaning of up to 5 analysis sieves Ø 200 mm in RK 1028 C /CH.</p>
	<p>Silicone knob mat SM ..., For the contact-free positioning of highly-sensitive instruments. Fastening inside the basket prevents the instruments from buoying upwards and being damaged. Permeable for ultrasound purposes.</p>
	<p>Fixing clamps FE 12, Set of 2 large and 5 small plastic clamps for the safe fixation of flexible endoscope accessories to the basket. Prevents damage to biopsy forceps and instruments</p>

Accessories Ultrasonic bath	Holding clamps for laboratory flasks	Handle adjustment	Test tube holder	Tabletting punch holder	Sieve holder	Silicone knob mat	Fixation clamps
RK 31 /H	-	-	-	-	-	-	-
RK 52 /H	EK 10, EK 25, EK 50, EK 100, EK 250	GV 3	RG 2	-	-	-	-
RK 100 /H, RK 102 H	EK 10, EK 25, EK 50, EK 100, EK 250	GV 3	RG 2	-	-	SM 3	-
RK 103 H	EK 10, EK 25, EK 50, EK 100, EK 250	GV 3	RG 2	-	-	-	-
RK 106	EK 10, EK 25, EK 50, EK 100, EK 250	-	-	-	SH 7	-	-
RK 156	EK 10, EK 25, EK 50, EK 100, EK 250	GV 3	-	-	-	SM 6	FE 12
RK 156 BH	EK 10, EK 25, EK 50, EK 100, EK 250	GV 3	-	-	-	SM 6	FE 12
RK 170 H	-	-	-	-	-	-	FE 12
RK 255 /H	EK 10, EK 25, EK 50, EK 100, EK 250	GV 3	-	-	-	SM 5	FE 12
RK 510 /H	EK 10, EK 25, EK 50, EK 100, EK 250	GV 10	-	-	-	-	-
RK 512 H	EK 10, EK 25, EK 50, EK 100, EK 250	GV 10	-	-	-	-	-
RK 514 /H	EK 10, EK 25, EK 50, EK 100, EK 250	GV 10		TH 14 B		SM 14	FE 12
RK 514 BH	EK 10, EK 25, EK 50, EK 100, EK 250	GV 10		TH 14 B-S 22 TH 14 B-S 28	-	-	-
RK 1028/H	EK 10, EK 25, EK 50, EK 100, EK 250	GV 10	-	TH 28-S 22 TH 28-S 28	-	SM 29	FE 12
RK 1028 C	EK 10, EK 25, EK 50, EK 100, EK 250	GV 10	-	-	SH 28 C	-	-
RK 1028 CH	EK 10, EK 25, EK 50, EK 100, EK 250	GV 10	-	TH 28 C TH 28 C-S 22 TH 28 C-S 28	-	-	-
RK 1040	-	-	-	-	-	-	-
RK 1050	-	-	-	-	-	-	-
RK 1050 CH	-	-	-	-	-	-	-

Information

Foil test

Testing of ultrasonic baths

A foil test¹ is recommended for testing ultrasonic baths. It is to be conducted upon initial startup, and at regular intervals thereafter (e.g. every 3 months). The frequency of testing is the responsibility of the user.

The foil test is a simple procedure to demonstrate the intensity and distribution of cavitation in an ultrasonic bath. To do so, aluminium foil is stretched over a foil test frame. It is perforated or destroyed to a certain degree by cavitation, depending on the duration.

For purposes of reproducibility, it is **important that the test conditions remain constant**:

- Fill level in the oscillating tank (¾)
- Temperature of tank contents
- Degassing time, if needed (degassing 5 to 30 min. before the test, depending on the tank contents)
Time may need to be extended with acidic cleaning solutions.
- Frame positioning
- Foil properties (thickness, surface)
- Sonication time
- Concentration and type of ultrasound preparation

Foils can be archived in a suitable way (scanning, photos, etc.)

This allows the foils to be compared at any time. The perforated areas of all foils should have approx. the same dimensions and distribution – the results are never identical.

A process validation, e.g. for the treatment of medical products, can only be achieved by conducting regular foil tests.

To execute the foil test, different foil test frames FT can be ordered from the manufacturer (for a fee). The foil test frames are suitable for a wide range of tank dimensions. Aluminium household foil is also required to conduct the test and is not included in the delivery.

Film: <http://bandelin.com/foilentest/>.

Fluid for the foil test

In order to obtain an adequately strong cavitation effect, the surface tension of the water used must also be reduced for the foil test with the help of surfactant preparations. We recommend the following ultrasound preparations: STAMMOPUR DR 8, STAMMOPUR R, TICKOMED 1, TICKOPUR R 33, TICKOPUR R 30, TICKOPUR TR 7

If none of these preparations is available, a neutral or mildly alkaline preparation that does not destroy aluminium may be used. The preparation must be approved by the manufacturer for use in ultrasonic baths.

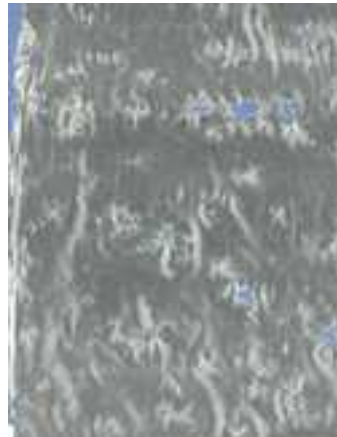

Example

¹ Investigations on test procedures for ultrasonic cleaners. IEC/TR 60886 (1987-03)

Conducting the foil test

1. Fill 2/3 of the oscillating tank with water and a suitable ultrasound preparation in the dosage specified by the manufacturer.
2. Degas the liquid: < 10 l - 10 min and > 10 l - 30 min (see user instructions.)
3. Stretch aluminium foil (household foil with a thickness of 10 µm to 25 µm) over the wire frame (stainless steel). Depending on the tank size, it is possible that the frame protrudes from the tank.
Covering the portion of the frame that is submerged will suffice.

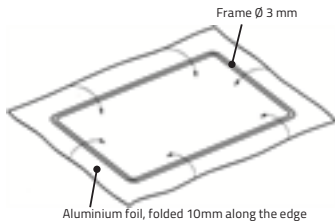

4. With the ultrasound switched off, place the foil-wrapped wire frame diagonally inside the oscillating tank, adjust if necessary.

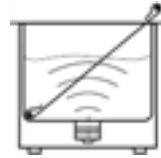

5. Switch on the ultrasound and sonicate the foil for at least one minute until visible perforations or holes are produced. With sturdier foils (thicker or coated ones), the sonication time can last up to 3 minutes.
6. Switch off the ultrasound, take the foil out and let it dry.
7. The foil must be perforated, otherwise contact the manufacturer.



8. Archive it together with testing date and the serial number of the ultrasonic bath.
9. After the test, the oscillating tank must be thoroughly rinsed out to remove any loose foil particles.

Type	for interior tank dimensions in mm (L x W x H)		Order No.	for
	from	to		
FT 1	190 x 85 x 60		3190	DT 31/H, DT 52/H RK 31/H, RK 52/H
FT 4	240 x 140 x 80	300 x 150 x 150	3074	DL 102 H, DL 255 H, DT 100/H, DT 102H/H-RC, DT 103, DT 106, DT 255/H/H-RC, RK 100/H, RK 102 H, RK 103, RK 106, RK 255/H
FT 6	500 x 140 x 100	500 x 140 x 150	3222	DL 156 BH, DT 156/BH, DT 1028 F RK 156/BH
FT 14	280 x 234 x 80	325 x 300 x 300	3084	DL 510 H, DL 512 H, DL 514 BH, DT 510/H/H-RC, DT 512 H, DT 514/H/BH/BH-RC, RK 510/H, RK 512 H, RK 514/HH/BH, ZE 514/...DT
FT 36	510 x 300 x 200/220		3673	ZE 1031/1032/...DT
FT 37	600 x 400 x 200/220		3674	DT 1058 M, ZE 1058/1059/...DT
FT 38	650 x 400 x 140/160		3672	MC 1001/E
FT 40	500 x 300 x 80	500 x 300 x 300	3094	DL 1028 H, DT 1028/H/CH, RK 170 H, RK 1028/H/C/CH, RK 1040
FT 42	700 x 420 x 160/190		3224	TRISON (TE 3000)
FT 45	600 x 400 x 200	600 x 400 x 200	3204	DT 1050 CH, RK 1050/CH

C Dosing table

The dosing table can be requested free of charge in DIN A4 format, or may be downloaded from the Internet as a PDF file.

<http://www.bandelin.com/dosier.htm>

Bath type	Fill quantity	Dosage	Dosage	Dosage	Dosage	Dosage
		1%	2%	3%	5%	10%
RK 31 /H	0.6 l	590 ml + 10 ml	585 ml + 15 ml	580 ml + 20 ml	570 ml + 30 ml	540 ml + 60 ml
RK 52 /H	1.2 l	1.1 l + 15 ml	1.1 l + 25 ml	1.1 l + 40 ml	1.1 l + 60 ml	1.0 l + 120 ml
RK 100 /H	2.0 l	1.9 l + 20 ml	1.9 l + 40 ml	1.9 l + 60 ml	1.9 l + 100 ml	1.8 l + 200 ml
RK 102 H	2.0 l	1.9 l + 20 ml	1.9 l + 40 ml	1.9 l + 60 ml	1.9 l + 100 ml	1.8 l + 200 ml
RK 103 H	2.7 l	2.6 l + 30 ml	2.6 l + 55 ml	2.6 l + 85 ml	2.5 l + 140 ml	2.4 l + 270 ml
RK 106	4.0 l	3.9 l + 40 ml	3.9 l + 80 ml	3.8 l + 120 ml	3.8 l + 200 ml	3.6 l + 400 ml
RK 156	4.0 l	3.9 l + 40 ml	3.9 l + 80 ml	3.8 l + 120 ml	3.8 l + 200 ml	3.6 l + 400 ml
RK 156 BH	6.0 l	5.9 l + 60 ml	5.8 l + 120 ml	5.8 l + 180 ml	5.7 l + 300 ml	5.4 l + 600 ml
RK 170 H	26.0 l	25.7 l + 260 ml	25.4 l + 520 ml	25.2 l + 780 ml	24.7 l + 1.3 l	23.4 l + 2.6 l
RK 255 /H	3.8 l	3.7 l + 40 ml	3.7 l + 80 ml	3.6 l + 120 ml	3.6 l + 190 ml	3.4 l + 380 ml
RK 510 /H	6.6 l	6.5 l + 70 ml	6.4 l + 140 ml	6.4 l + 200 ml	6.2 l + 330 ml	5.9 l + 660 ml
RK 512 H	8.7 l	8.6 l + 90 ml	8.5 l + 180 ml	8.4 l + 270 ml	8.2 l + 440 ml	7.8 l + 870 ml
RK 514 /H	9.0 l	8.9 l + 90 ml	8.8 l + 180 ml	8.7 l + 270 ml	8.5 l + 450 ml	8.1 l + 900 ml
RK 514 BH	12.5 l	12.3 l + 130 ml	12.2 l + 250 ml	12.1 l + 380 ml	11.8 l + 630 ml	11.2 l + 1.3 l
RK 1028 /H	19.0 l	18.8 l + 190 ml	18.6 l + 380 ml	18.4 l + 570 ml	18.0 l + 950 ml	17.1 l + 1.9 l
RK 1028 C /CH	30.0 l	29.7 l + 300 ml	29.4 l + 600 ml	29.1 l + 900 ml	28.5 l + 1.5 l	27.0 l + 3.0 l
RK 1040	28.0 l	27.7 l + 280 ml	27.4 l + 560 ml	27.1 l + 840 ml	26.6 l + 1.4 l	25.2 l + 2.8 l
RK 1050	41.0 l	40.5 l + 410 ml	40.1 l + 820 ml	39.7 l + 1.3 l	38.9 l + 2.1 l	36.9 l + 4.1 l
RK 1050 CH	60.0 l	59.4 l + 600 ml	58.8 l + 1.2 l	58.2 l + 1.8 l	57.0 l + 3.0 l	54.0 l + 6.0 l

/Number in standard print: Water

Number in **bold** print: Preparation

Numbers have been rounded.

If a sample vessel was used, the dosage can be calculated as follows:
Example:

- 10 litres ready-made solution
- 2.5 % dosing of the preparation

$$\frac{10 \text{ l} \times 2.5 \%}{100 \%} = 0.25 \text{ l preparation}$$

$$10 \text{ l} - 0.25 \text{ l} = 9.75 \text{ l water}$$

Note:

These and further languages of this user instructions, as well as further information are to be found on the enclosed CD.